

SCREW: NONE	MATERIAL: COPPER	REV: H	 800-776-9775 www.ilSCO.com
CAT. NO.: SEE CHART	PLATING: EL-TIN	DRAWN BY:DW SCALE: NTS	
INFORMATION SHEET:FORM 157	MARKING: SEE CHART	DATE:6/3/2008 SIZE: B	
			DWG NO: Y0603-S-9
			SHEET: 1 OF 1

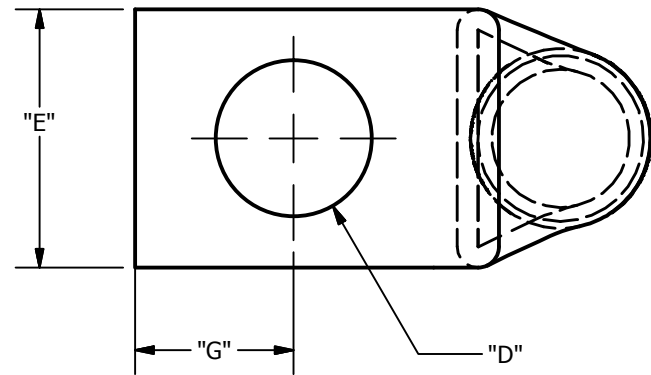

DETAIL E
INK MARK TOP & BOTTOM

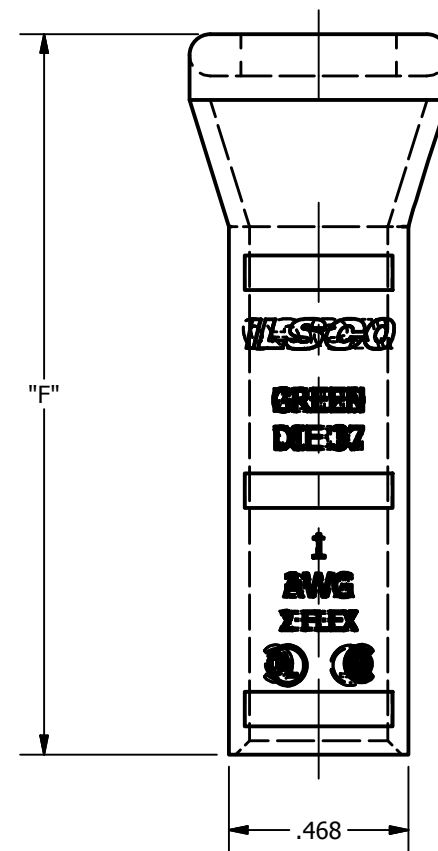
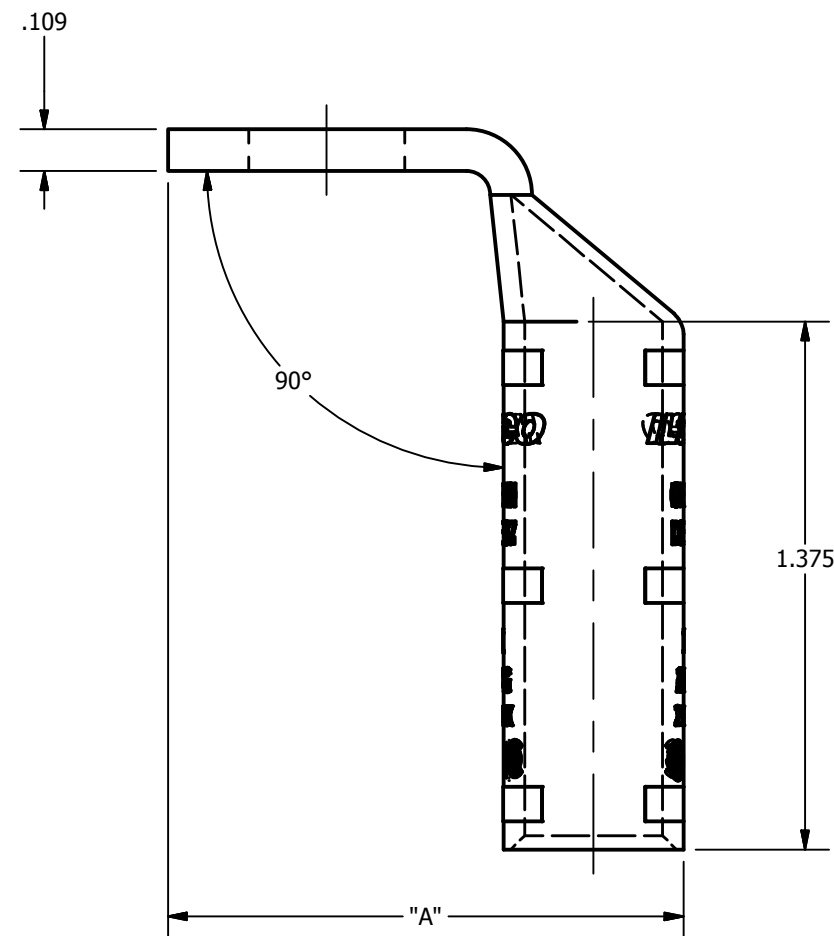

CATALOG NUMBER	"A"	"D"	"E"	"F"	"G"	TANG MARKING
CLNB-1-10-9	1.139	0.219	0.673	1.917	0.257	ILSCO, C-1-10-9, 1 AWG, 2 FLEX, DIE 37, UL, CSA
CLNB-1-14-9	1.452	0.281	0.673	1.920	0.320	ILSCO, C-1-14-9, 1 AWG, 2 FLEX, DIE 37, UL, CSA
CLNB-1-12-9	1.827	0.562	0.750	1.920	0.546	ILSCO, CLNB-1-12-9, 1 AWG, 2 FLEX, DIE 37, UL, CSA
CLNB-1-38-9	1.452	0.406	0.673	1.920	0.414	
CLNB-1-516-9	1.452	0.343	0.673	1.920	0.351	ILSCO, CLNB-1-516-9, 1 AWG, 2 FLEX, DIE 37, UL, CSA